



Toughsheet[™]
Building Products

Post Profile Drawings

Toughtimber

01942 841111

sales@toughsheet.co.uk

Chequerbent Works,
Manchester Rd, Bolton,
United Kingdom

www.toughsheet.co.uk

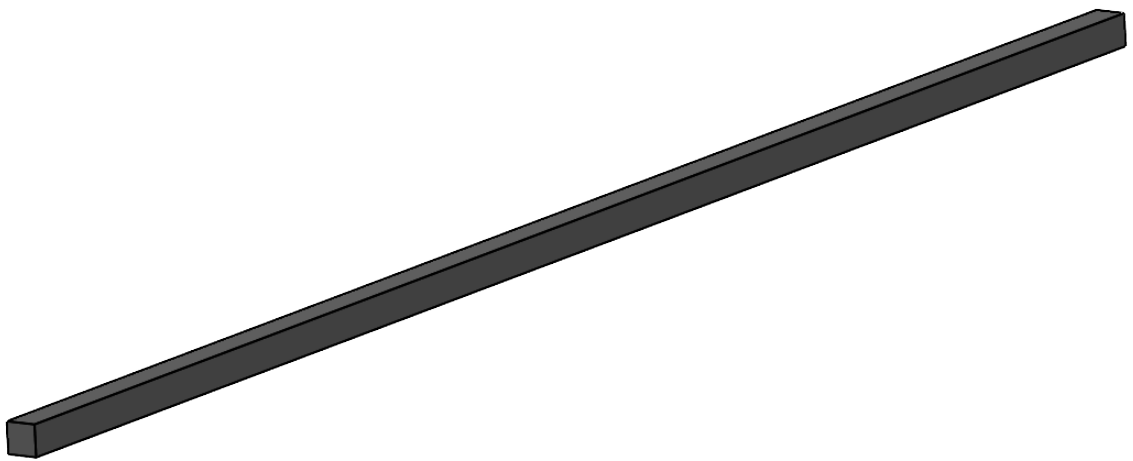
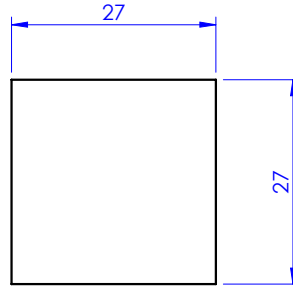

Note:

- Dimension given in the drawing are the **nominal dimensions** of the lumber. Dimensions of the final part will suffer **shrinkage** during the cooling process.
- Shrinkage rate within **2-4%** (depends of the material).



Zona Ind. dos Pousos
Apartado 523
2416-904 Leiria
PORTUGAL
T +351 244 859 990
F +351 244 859 999
comercial@periplast.pt
www.periplast.pt

Escala
1:1

Peso [Kg]

Área [m²]
0

| Tolerâncias Gerais | |
|--------------------|----------|
| Maquinações | ± 0,1 mm |
| Geral | ± 1 mm |

Cliente
Frank Mercer & Sons Ltd

Marcação
OB2491-27x27

Quant.
1

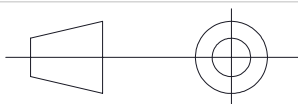

| | Data | Nome |
|----------------|------------|---------|
| Desenhou | 15/10/2024 | Jean S. |
| Verificou | | |
| Aprovou | | |
| Data Impressão | 15/10/2024 | |

Descrição

Obra Periplast: - Obra Poço: -
-
27x27 - approval drawing

| Rev | Alteração | Data | Nome |
|-----|-----------|------|------|
| | | | |



| Revisão | Folha | Página |
|----------|-----------|----------|
| 0 | A4 | 1 |

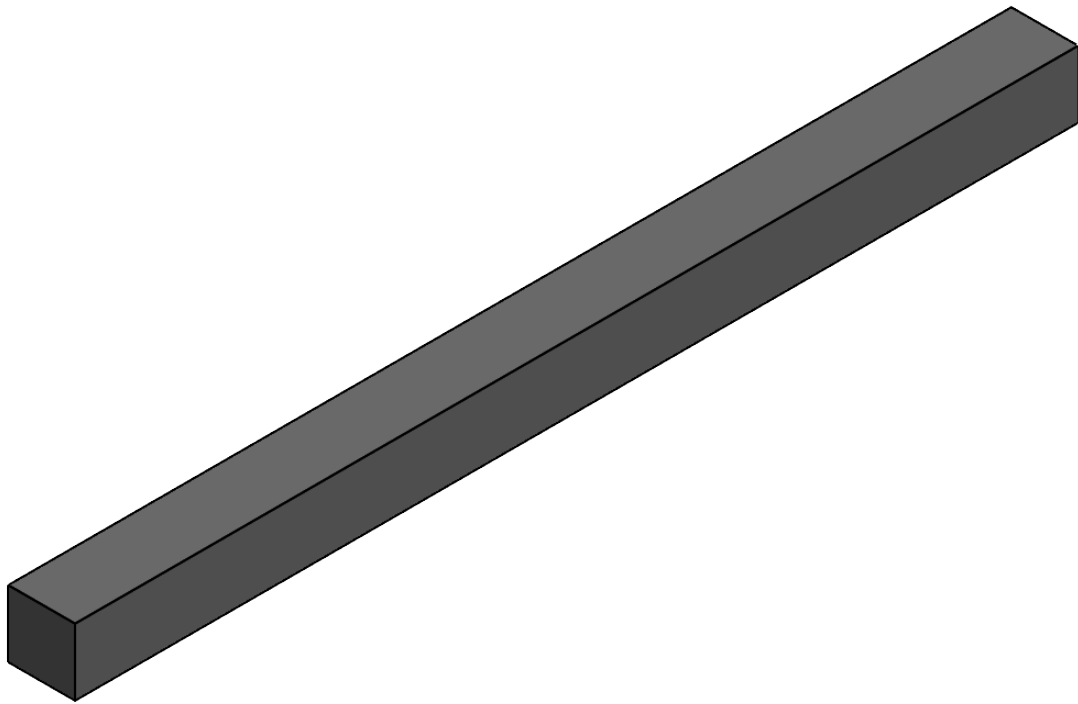
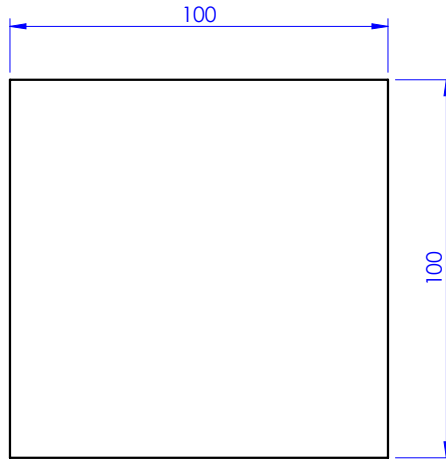

Note:

- Dimension given in the drawing are the **nominal dimensions** of the lumber. Dimensions of the final part will suffer **shrinkage** during the cooling process.
- Shrinkage rate within **2-4%** (depends of the material).



Zona Ind. dos Pousos
Apartado 523
2416-904 Leiria
PORTUGAL
T +351 244 859 990
F +351 244 859 999
comercial@periplast.pt
www.periplast.pt

Escala
1:2

Peso [Kg]

Área [m²]
0

| Tolerâncias Gerais | |
|--------------------|----------|
| Maquinações | ± 0,1 mm |
| Geral | ± 1 mm |

Cliente
Frank Merce & Sons Ltd

Marcação
OB2491-100x100

Quant.
1

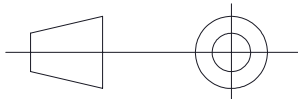

| | Data | Nome |
|----------------|------------|---------|
| Desenhou | 15/10/2024 | Jean S. |
| Verificou | | |
| Aprovou | | |
| Data Impressão | 15/10/2024 | |

Descrição

Obra Periplast: - Obra Poço: -
-
100x100 - approval drawing

| Rev | Alteração | Data | Nome |
|-----|-----------|------|------|
| | | | |



| | | |
|---------------------|--------------------|--------------------|
| Revisão 0 | Folha A4 | Página 1 |
|---------------------|--------------------|--------------------|

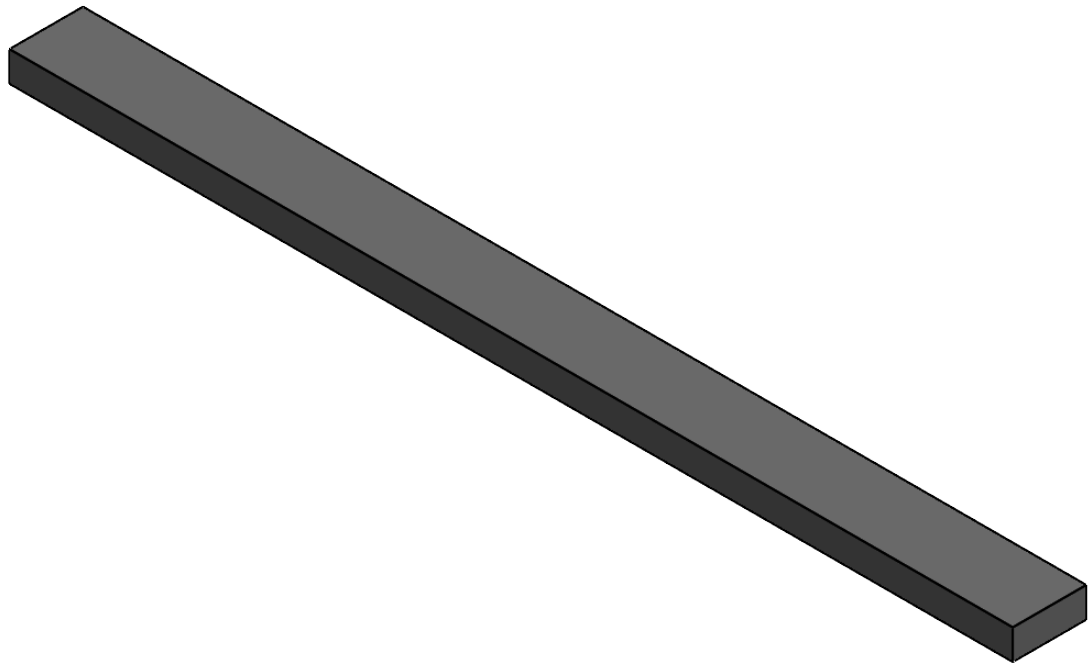
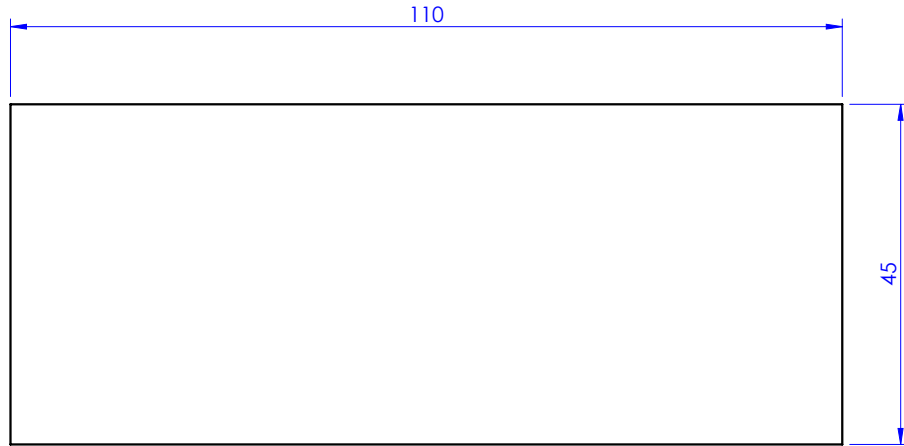

Note:

-Dimension given in the drawing are the **nominal dimensions** of the lumber. Dimensions of the final part will suffer **shrinkage** during the cooling process.
-Shrinkage rate within **2-4%** (depends of the material).



Zona Ind. dos Pousos
Apartado 523
2416-904 Leiria
PORTUGAL
T +351 244 859 990
F +351 244 859 999
comercial@periplast.pt
www.periplast.pt

Escala
1:1

Peso [Kg]

Área [m²]
0

| Tolerâncias Gerais | |
|--------------------|----------|
| Maquinações | ± 0,1 mm |
| Geral | ± 1 mm |

Cliente
Frank Mercer & Sons Ltd

Marcação
OB2491-110x45

Quant.
1

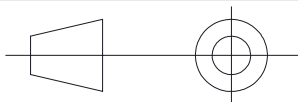

| | Data | Nome |
|----------------|------------|---------|
| Desenhou | 15/10/2024 | Jean S. |
| Verificou | | |
| Aprovou | | |
| Data Impressão | 15/10/2024 | |

Descrição

Obra Periplast: - Obra Poço: -
-
110x45 - approval drawing

| Rev | Alteração | Data | Nome |
|-----|-----------|------|------|
| | | | |



| | | |
|---------------------|--------------------|--------------------|
| Revisão 0 | Folha A4 | Página 1 |
|---------------------|--------------------|--------------------|

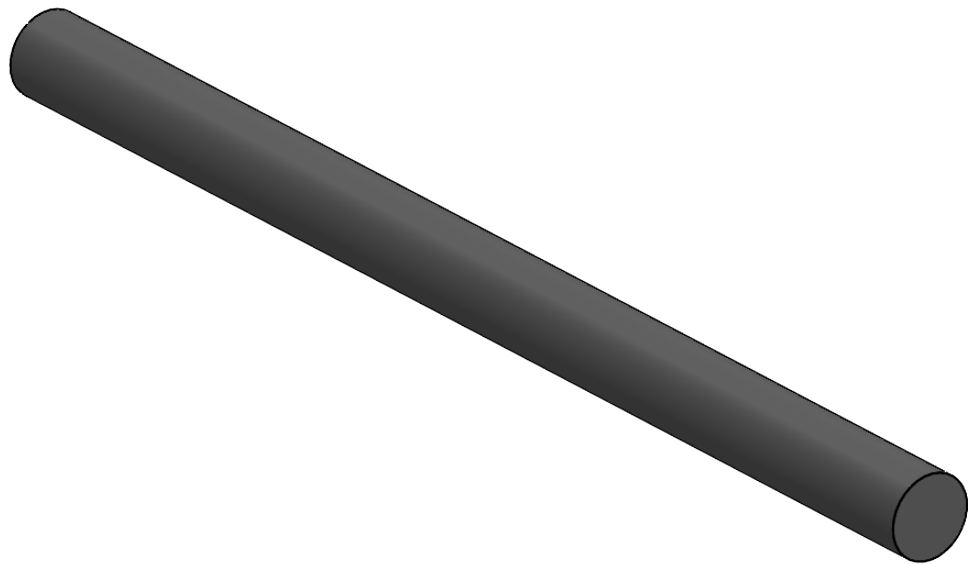
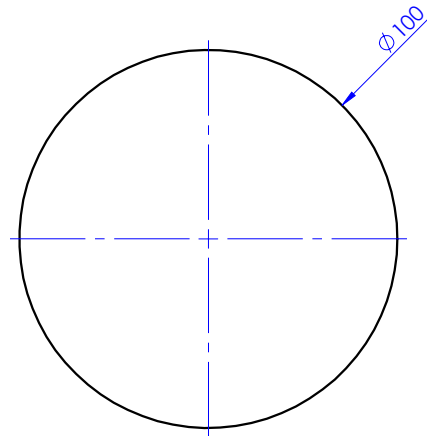

Note:

- Dimension given in the drawing are the **nominal dimensions** of the lumber. Dimensions of the final part will suffer **shrinkage** during the cooling process.
- Shrinkage rate within **2-4%** (depends of the material).



Zona Ind. dos Pousos
Apartado 523
2416-904 Leiria
PORTUGAL
T +351 244 859 990
F +351 244 859 999
comercial@periplast.pt
www.periplast.pt

| | | | |
|---|-----------|------------------------------------|--|
| Escala 1:2 | Peso [Kg] | Área [m ²] 0 | Tolerâncias Gerais Maquinações ±0,1 mm Geral ±1 mm |
| Cliente Frank Mercer & Sons Ltd | | Marcação OB2491-Ø100 | Quant. 1 |

| | | | |
|-----|-----------|----------------|------------|
| | | Data | Nome |
| | Desenhou | 15/10/2024 | Jean S. |
| | Verificou | | |
| | Aprovou | | |
| | | Data Impressão | 15/10/2024 |
| Rev | Alteração | Data | Nome |

| | |
|-----------|--|
| Descrição | Obra Periplast: - Obra Poço: - - Ø100 - approval drawing |
| Revisão | 0 |
| Folha | A4 |
| Página | 1 |

1

2

3

4

A

100x25

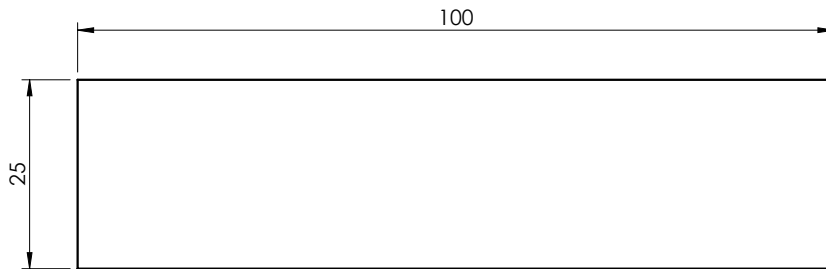

B

C

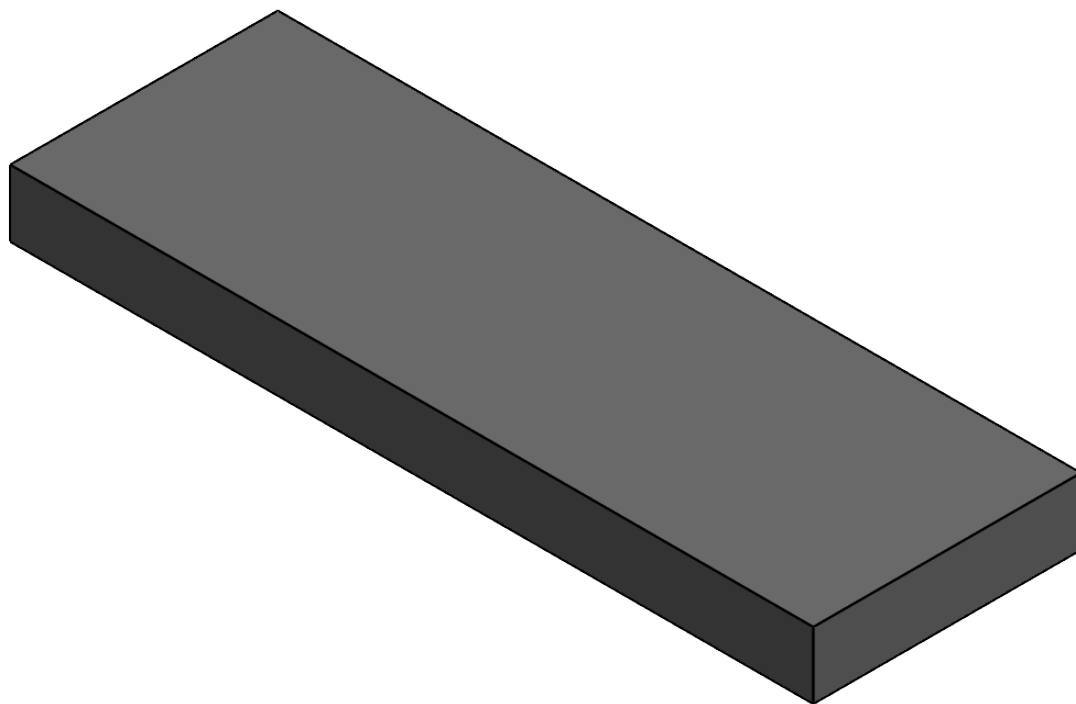

D

E

| | | | | | | | | |
|---|-----------|---|---|----------------------|--------------------------|-----------------------------|--|--------------------|
|  | | Rua de Marrazes, Lote 32 Zicofa 2415-807 Leiria PORTUGAL T +351 244 859 990 F +351 244 859 999 comercial@periplast.pt www.periplast.pt | | Escala 1:1 | Peso [Kg] 0.71 | Área [m ²] - | Tolerâncias Gerais Maquinações ±0,1 mm Geral ±1 mm | |
| | | Cliente | | Marcação - | | Quant. 1 | | |
|  | | Data Nome | Descrição Obra Periplast: Obra Poço: 100x25 - approval drawing | | | | | |
| | | Desenhou 14/02/2024 - | | | | | | |
| | | Verificou | | | | | | |
| | | Aprovou | | | | | | |
| | | Data Impressão 14/02/2024 | | | | | | |
| | |  | | | | Revisão - | Folha A4 | Página 1 |
| Rev | Alteração | | | | | Data | Nome | |

F

1

2

3

4

A

150x25 T&G

B

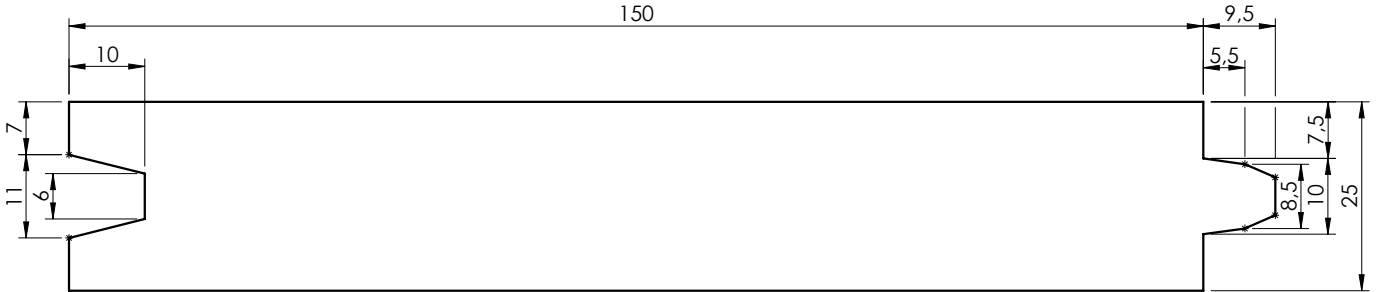

C

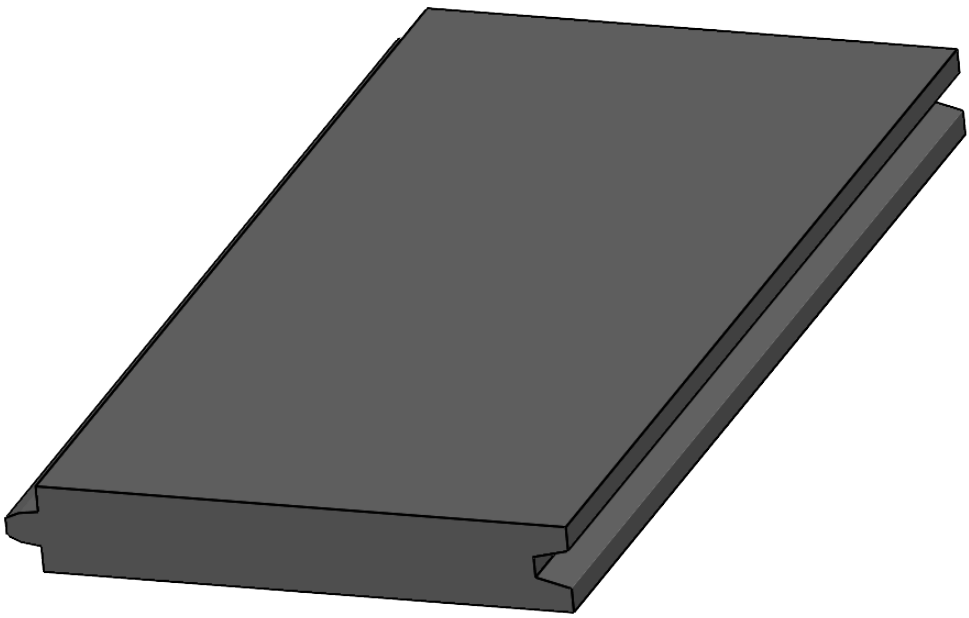

D

E

| | | | | | | | | |
|-----|---|----------------------------------|----------------------|--|--|--|--------------------|--------------------|
| | Rua de Marrazes, Lote 32 Zicofa 2415-807 Leiria PORTUGAL T +351 244 859 990 F +351 244 859 999 comercial@periplast.pt www.periplast.pt | | Escala 1:1 | Peso [Kg] 1.07 | Área [m ²] 121562.46 | Tolerâncias Gerais Maquinações ±0,1 mm Geral ±1 mm | | |
| | | | Cliente | Marcação - | | Quant. 2 | | |
| | | Data 14/02/2024 | Nome - | Descrição Obra Periplast: Obra Poço: 150x25 T&G - approval drawing | | | | |
| | | Desenhou | | | | | | |
| | | Verificou | | | | | | |
| | | Aprovou | | | | | | |
| | | Data Impressão 14/02/2024 | | | | | | |
| Rev | Alteração | Data | Nome | Revisão - | | | Folha A4 | Página 1 |

F

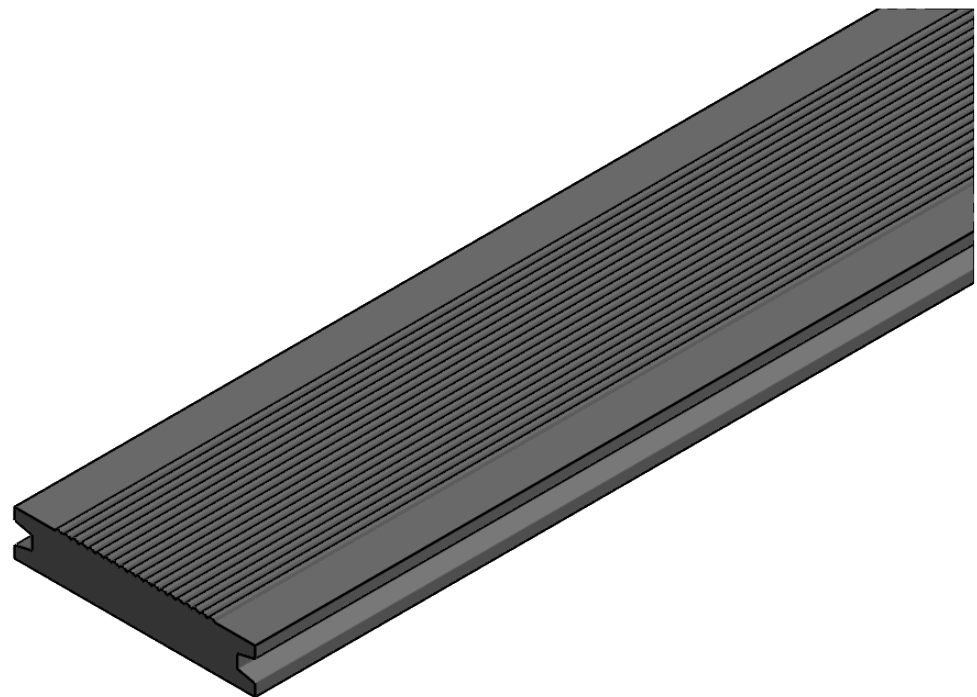
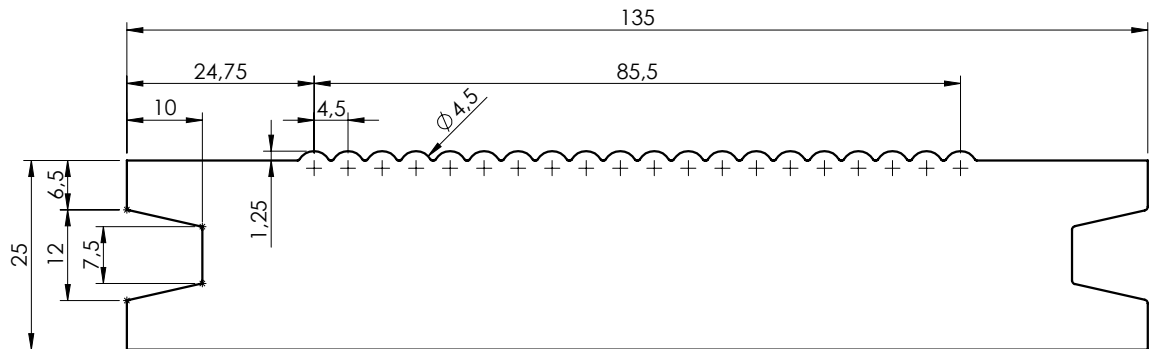

periplast
extrusion expertise

Rua de Marrazes, Lote 32
Zicofa
2415-807 Leiria
PORTUGAL
T +351 244 859 990
F +351 244 859 999
comercial@periplast.pt
www.periplast.pt

| | | | |
|----------------------|---------------------------|-----------------------------|--|
| Escala 1:1 | Peso [Kg] 12.38 | Área [m ²] - | Tolerâncias Gerais Maquinações ±0,1 mm Geral ±1 mm |
| Cliente | Marcação - | Quant 2 | |

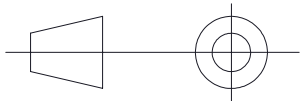

| | | |
|----------------|------------|------|
| | Data | Nome |
| Desenhou | 14/02/2024 | - |
| Verificou | | |
| Aprovou | | |
| Data Impressão | 14/02/2024 | |

Descrição
**Obra Periplast: Obra Poço:
135x25 decking w/ grooves - approval
drawing**

| | | | | | | | | |
|-----|-----------|------|------|--|--|--------------|--------------------|--------------------|
| Rev | Alteração | Data | Nome | | | Revisão - | Folha A4 | Página 1 |
|-----|-----------|------|------|--|--|--------------|--------------------|--------------------|

A

Decking 125 x 25

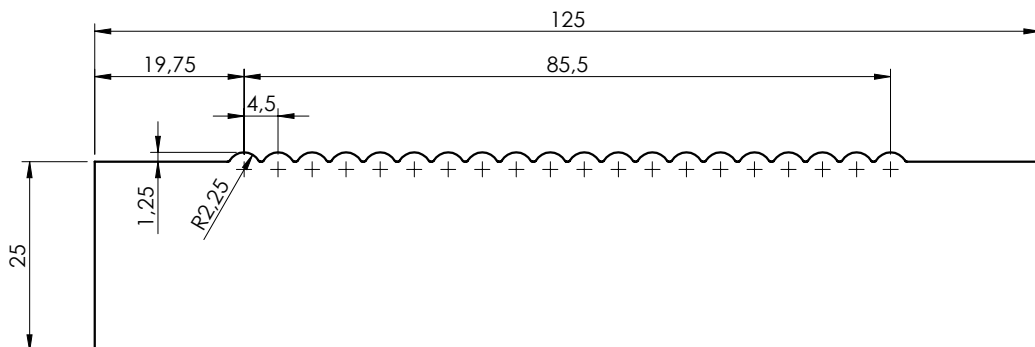

B

C

D

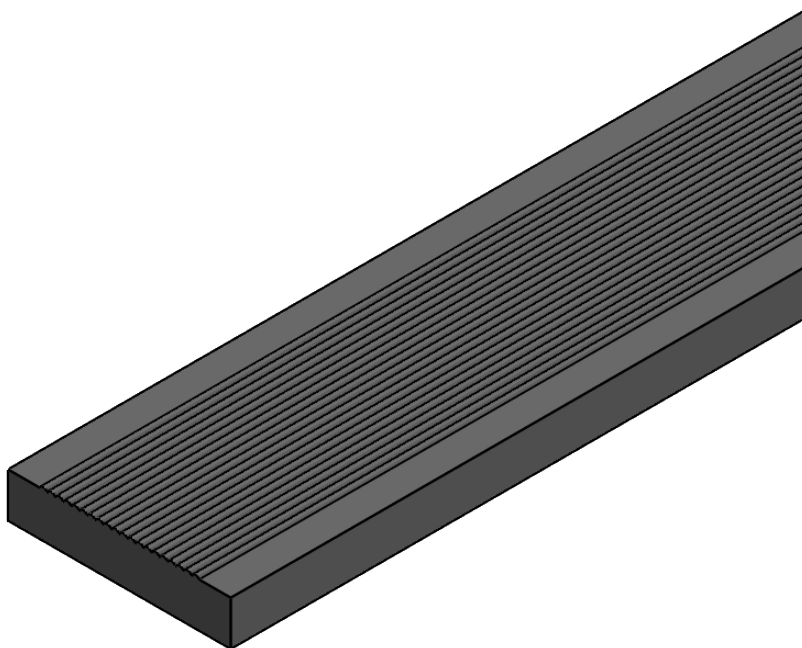

E

| | | | | | | |
|-----|---|---------------------------|--|---------------------------|----------------|--|
| | Rua de Marrazes, Lote 32 Zicofa 2415-807 Leiria PORTUGAL T +351 244 859 990 F +351 244 859 999 comercial@periplast.pt www.periplast.pt | | Escala 1:1 | Peso [Kg] 12.18 | Área [m²] - | Tolerâncias Gerais Maquinações ±0,1 mm Geral ±1 mm |
| | | | Cliente | Marcação - | | Quant. 2 |
| | | Data Nome | Descrição <p style="text-align: center;">Obra Periplast: Obra Poço: 125x25 decking - approval drawing</p> | | | |
| | | Desenhou 06/02/2024 - | | | | |
| | | Verificou | | | | |
| | | Aprovou | | | | |
| | | Data Impressão 06/02/2024 | | | | |
| Rev | Alteração | Data | Nome | | | Revisão - |
| | | | | | | Folha A4 |
| | | | | | | Página 1 |

F

A

Round Ø90

B

C

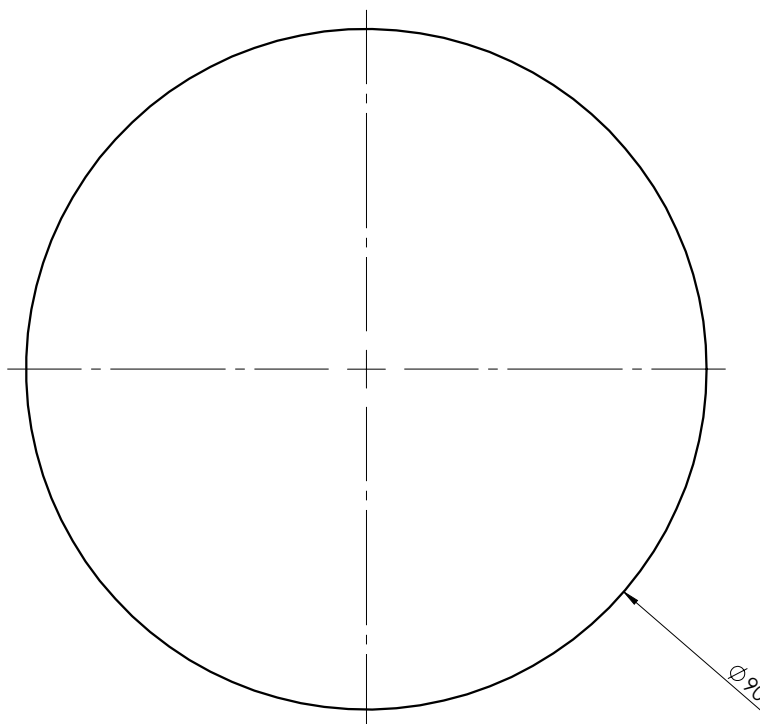

D

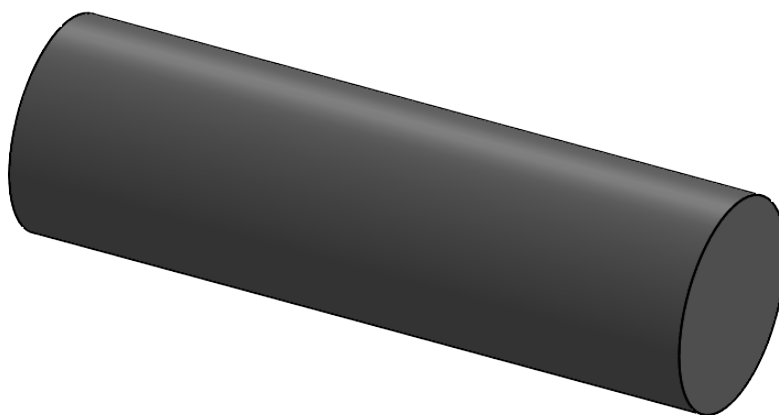

E

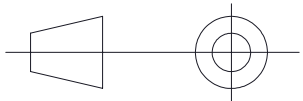
| | | | | | | |
|---|---|------------------------------|----------------------------------|---|---|--|
|  | Rua de Marrazes, Lote 32 Zicofa 2415-807 Leiria PORTUGAL T +351 244 859 990 F +351 244 859 999 comercial@periplast.pt www.periplast.pt | | Escala 1:1 | Peso [Kg] 1.82 | Área [m ²] 97546.45 | Tolerâncias Gerais Maquinações ±0,1 mm Geral ±1 mm |
| | | | Cliente | Marcação - | | Quant. 1 |
|  | | | Data Nome | Descrição <p style="text-align: center;">Obra Periplast: Obra Poço: Round Ø90 - approval drawing</p> | | |
| | | Desenhou 14/02/2024 - | | | | |
| | | Verificou | | | | |
| | | Aprovou | | | | |
| | | | Data Impressão 14/02/2024 | | | |
| Rev | Alteração | Data | Nome | Revisão - | | Folha A4 |
| | | | | Página 1 | | |

F

A

Round Ø70

B

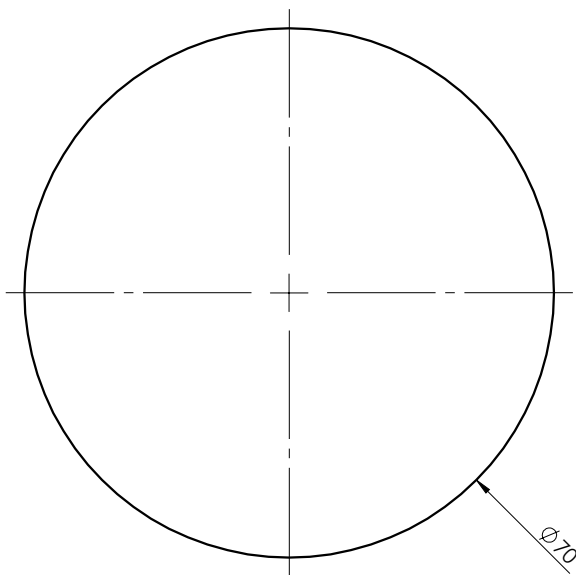

C

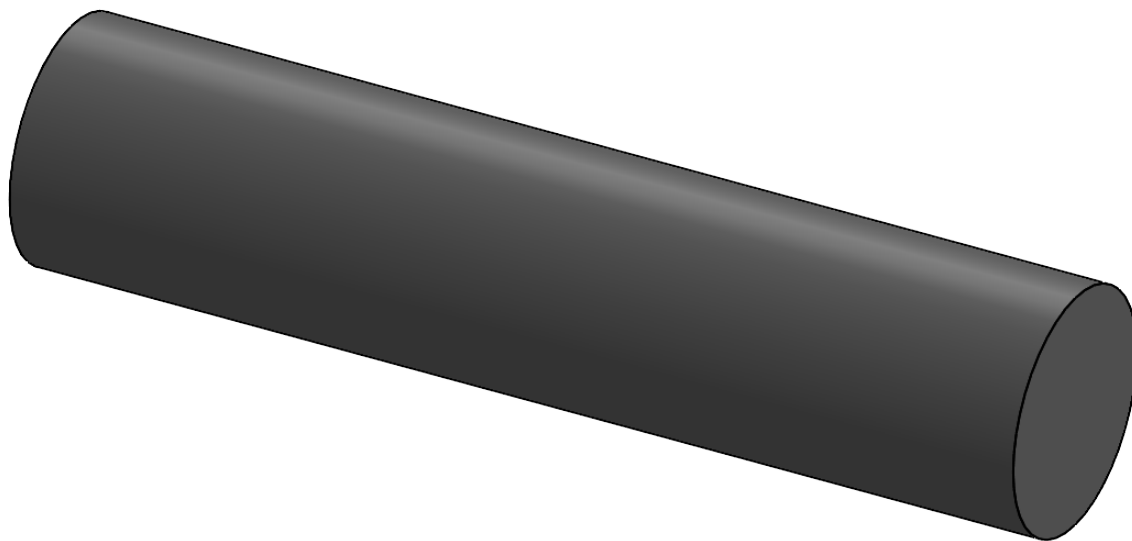

D

E

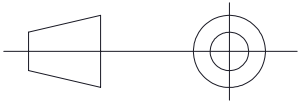
| | | | | | | |
|---|---|---|----------------------|--------------------------|---|--|
|  | Rua de Marrazes, Lote 32 Zicofa 2415-807 Leiria PORTUGAL T +351 244 859 990 F +351 244 859 999 comercial@periplast.pt www.periplast.pt | | Escala 1:1 | Peso [Kg] 1.10 | Área [m ²] 73670.35 | Tolerâncias Gerais Maquinações ±0,1 mm Geral ±1 mm |
| | | | Cliente | Marcação - | | Quant. 1 |
|  | Data Nome | Descrição <p style="text-align: center;">Obra Periplast: Obra Poço: Round Ø70 - approval drawing</p> | | | | |
| | Desenhou 14/02/2024 - | | | | | |
| | Verificou | | | | | |
| | Aprovou | | | | | |
| | Data Impressão 14/02/2024 | | | | | |
| | | | | | | |
| Rev. Alteração Data Nome | | | | | Revisão - | Folha A4 |
| | | | | | | Página 1 |

F

1

2

3

4

A

90x90

90

B

90

C

D

E

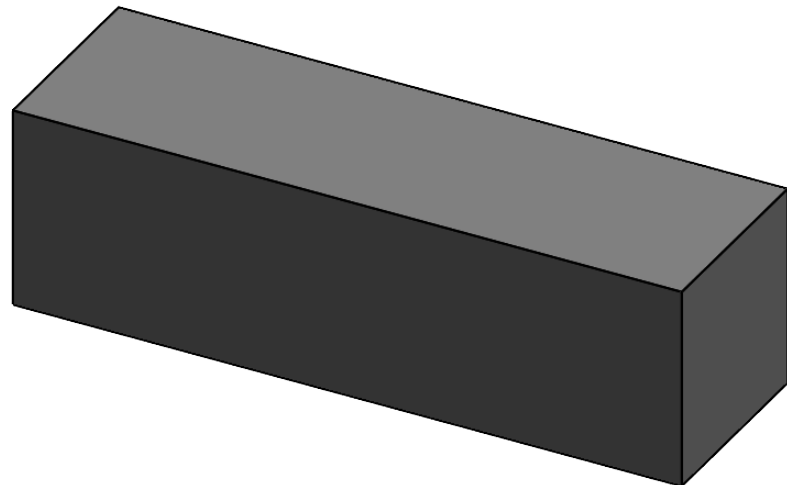

F



Rua de Marrazes, Lote 32
 Zicofa
 2415-807 Leiria
 PORTUGAL
 T +351 244 859 990
 F +351 244 859 999
 comercial@periplast.pt
 www.periplast.pt

| | | | |
|----------------------|--------------------------|---|--|
| Escala 1:1 | Peso [Kg] 2.31 | Área [m ²] 124200 | Tolerâncias Gerais Maquinações ±0,1 mm Geral ±1 mm |
| Cliente | | Marcação - | Quant. 1 |

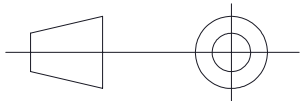

| | Data | Nome |
|----------------|------------|------------|
| Desenhou | 14/02/2024 | - |
| Verificou | | |
| Aprovou | | |
| Data Impressão | | 14/02/2024 |

Descrição
**Obra Periplast: Obra Poço:
 90x90 - approval drawing**

| | | | | | | | |
|-----|-----------|------|------|--|--------------|--------------------|--------------------|
| Rev | Alteração | Data | Nome | | Revisão - | Folha A4 | Página 1 |
| | | | | | | | |